

CAD FILE:

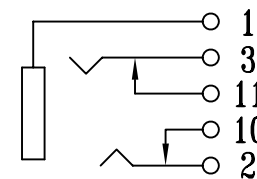

SCHEMATIC

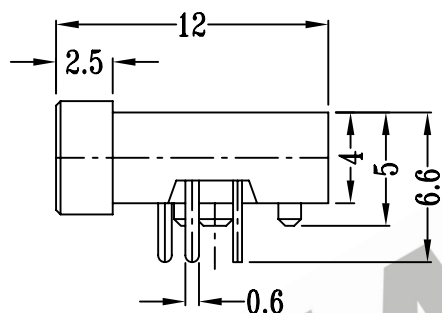
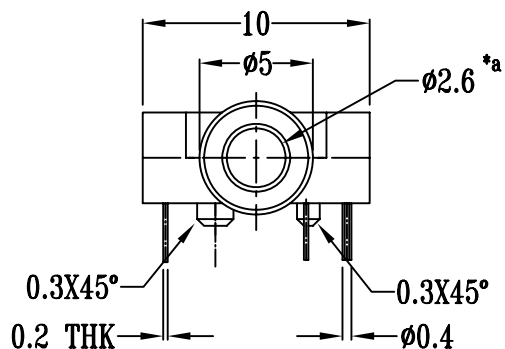
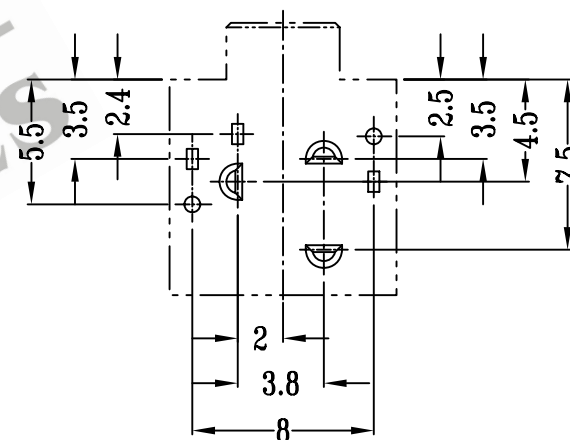
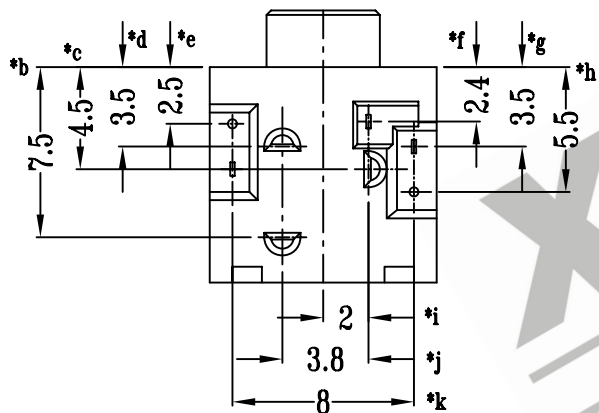

P.C.B LAYOUT

注:带*表示关键尺寸(11个)

8	WIRE PLATE E	PBS WIRE	1&2	Ag PLATED	TOLERANCE UNLESS SPECIFIED	SHENZHEN XIEJIA ELECTRONICS CO.,LTD.				
7	SPRING TERMINAL C	PBS STRIP	1	Ag PLATED OVER Ni PLATED						
6	CASE	NYLON66+94V0	1	BLACK	WITHIN: 1.5±0.1mm	ISSUE	DATE	DESCRIPTIONS OF REVISION		APPD.
5	COVER	NYLON+94V0/NYLON+F.G+94V0	1	CLEAR	OVER: 1.5±0.2mm					
4	SLEEVE	NYLON	1	BLACK	TITLE : PHONE JACK		UNIT : mm	DRWG NO.: XJ-DR-ST102A06-00		
3	SPRING TERMINAL B	PBS STRIP	1	Ag PLATED OVER Ni PLATED	MODEL: ST-102A-06		SCALE: 3:1	DWN.	ZHOUYU	2004-2-26
2	TERMINAL A	PBS STRIP	1	Ag PLATED OVER Ni PLATED	ALL MATERIALS MUST BE COMPLIANT TO ROHS			CHK'D	FANGYING	2004-2-26
1	WIRE PLATE D	PBS WIRE	1&2	Ag PLATED				APPD.	KANGXINAN	2004-2-26
NO.	PARTS	MATERIALS	Q'TY	FINISH						